

AKIRA
makes life better

Air Conditional Service Manual



Большая библиотека технической документации

<https://splitsystema48.ru/instrukcii-po-ekspluatacii-kondicionerov.html>

каталоги, инструкции, сервисные мануалы, схемы.

Model:
AC-F30HG

CONTENTS

SPECIFICATIONS	4
OUTLINE & DIMENSIONS.....	6
EXPLODED VIEW & PART LIST	8
INSTALLATION GUIDE.....	13
CIRCUIT DIAGRAM.....	28
PCB FUNCTION MANUAL	29

SPECIFICATION

MODEL		COOLING	HEATING
Power Supply		3Ph 380V 50Hz	
Capacity	W	7000	7400
Rated input	W	2900	2600
Rated current	A	6.0	5.7
Air flow	M ³ /h	900	
Dehumidifying volume (L/h)	L/h	2.8	
EER (W/W)		2.35	2.85
Indoor unit	Motor Model	LN50B	
	Motor fan speed (r/min)	385/355/315	
	Output power (W)	50	
	Working capacitor (muf F)	4.5	
	Fan type/piece	Centrifugal fan-1	
	Diameter-length (mm)	378-130	
	evaporator	Aluminum fin-copper tube	
	Row-fin distance (mm)	2-1.5	
	Working area (mm x mm)	763 x 430	
	Swing motor	SM016	
	Input power (W) speed (r/min)	5-5	
	Fuse (A)	Controllor 3.15A Transformer 0.2A	
	Noise (dB(A))	48	
	Dimension (width-depth-height)mm	540 x 300 x 1750	
Net weight (kg)	50		

Outdoor unit	Compressor	type		Reciprocating compressor
		Model		AVA5535EXG
		Input power (W)		2842
		Overload protector		Out set
		L.R.A. (A)		33
		Working temp.		Exhaust temperature $\leq 143.3^{\circ}\text{C}$
		Starting method		
	Condensor	Condensor		Aluminum-copper
		Pipe-diameter		$\Phi 9.52$
		Row-fin distance		2-1.8
		Working area (mm x mm)		840 x 760
	Fan	Fan motor model		LW60B
		Output power		60
		Fan motor speed (rpm)		780
		Capacitor mui F		3
		Fan type/piece		Axial fan-1
		Fan diameter (mm)		$\Phi 455$
	High pressure switch	Model		HZOPS-B3.0/2.4Mpa or YK-3.0/2.4Mpa
		Cutoff pressure		$3.0 \pm 0.15\text{Mpa}$
		Restart pressure		$2.4 \pm 0.15\text{Mpa}$
Throttling method			Capillary	
Defrosting method			Auto defrost	
Noise dB(A)			58	
Dimension (mm) (Width-height-depth)			950 x 840 x 412	
Net weight (Kg)			75	
Refrigerant charge (kg)			R22 2.5	
Connecting pipe	Outer diameter	Liquid pipe	mm	$\Phi 3/8''$
		Gas pipe	mm	$\Phi 5/8''$
	Standard length		m	5
	Max distance	Height	m	15
		Length	m	40

OUTLINE AND DIMENSIONS

INDOOR UNIT

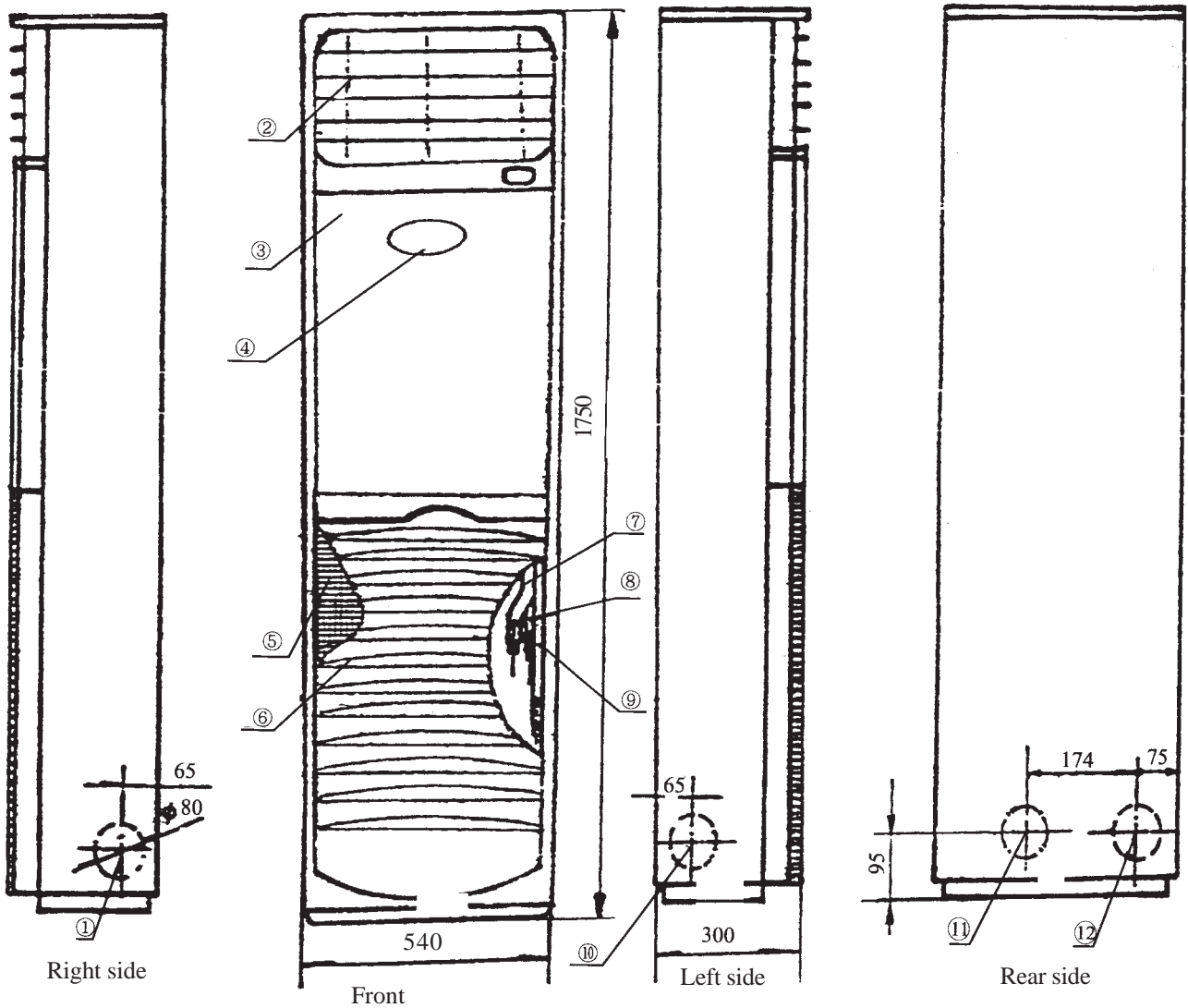
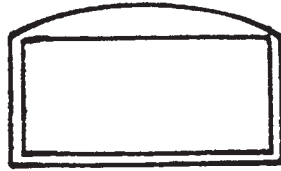

- | | |
|-----------------------------|----------------------------|
| ① Right knock-out hole | ② Grille |
| ③ Front panel | ④ Controller |
| ⑤ Filter | ⑥ Air intake grille |
| ⑦ Gas pipe | ⑧ Liquid pipe |
| ⑨ Drainage hose | ⑩ Left knock-out hole |
| ⑪ Rear right knock-out hole | ⑫ Rear left knock-out hole |

OUTLINE AND DIMENSIONS

OUTDOOR UNIT

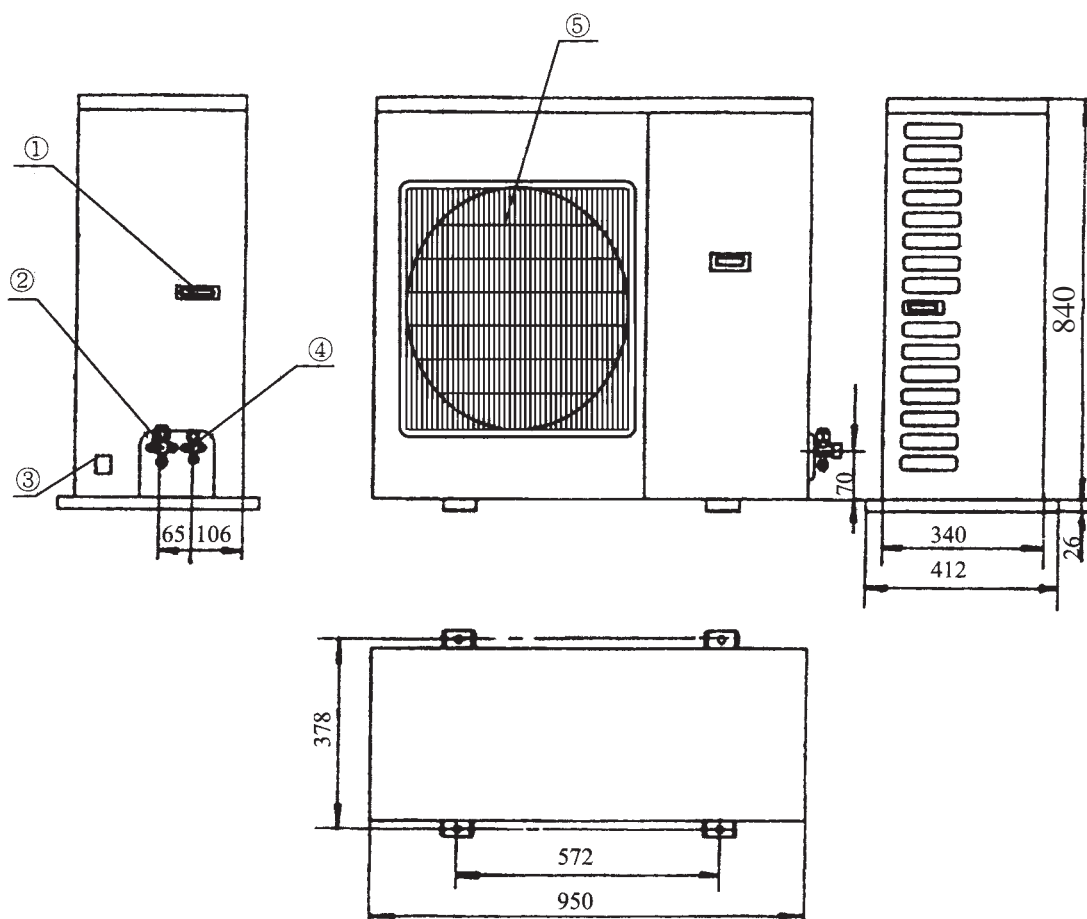

- ① Handle ② Gas valve assy ③ Wire hole ④ Liquid valve assy ⑤ Grille

EXPLOSIVE VIEW AND PARTS LIST

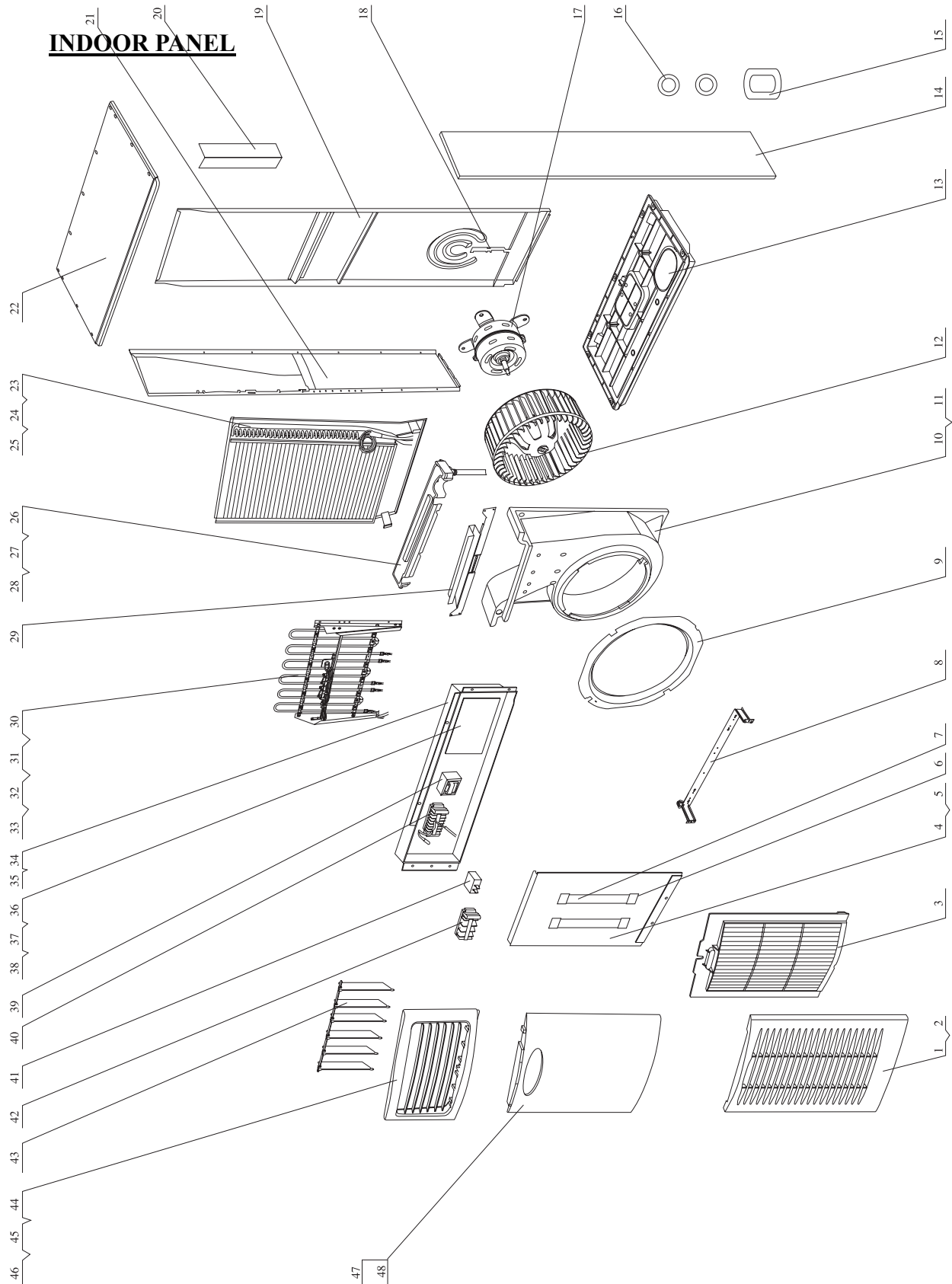

Model No: AC-F30HG
Version 1.0

INDOOR PANEL

No.	Description	Part No	Qty
1	Air Intake Assy	20004202	1
2	Chain	70814001	1
3	Filter Assy	11124071	1
4	Air Guard Assy	01364241	1
5	Lamp	\	2
6	Rectifier	\	1
7	Lamp Seat	\	4
8	Lower Baffle	01384216	1
9	Diversion Circle	10374202	1
10	Propeller House	12104240	1
11	Foam Fixed Screw	70110003	9
12	Centrifugal Fan	10314201	1
13	Underpan	22224201	1
14	Right Side Plate	01304202	1
15	Pipe-crossing Loop	76514421	1
16	Cable-crossing Loop	76514425	2
17	Fan Motor LN50B	15014205	1
18	Cable-pressed Plate	01384201	1
19	Rear Plate	01304241	1
20	Protective Cover	22244231	1
21	Left Side Plate	01304201	1
22	Top Cover Assy	22244230	1
23	Evaporator Assy	01004220	1
24	Seal Ring	76514202	1
25	Sensor Insert	42020063	1
26	Water Tray Assy	12414210	1
27	Drainage Pipe	05235433	1
28	Breakwater	01364210	1
29	Water Tray Support	01274210	1
30	Assistant Heater Assy	32004202	1
31	Temperature Limiter 65	46010505	1
32	Fuse 99 10A	46010355	2
	Fuse 98 (G4A01098C)	46010302	2
33	Electric Heater 850W	32014007	3
34	Electric Box Assy	01404211	1

No.	Description	Part No	Qty
35	Electric Box Cover	01404221	1
36	PCB 3453F	30023048	1
	PCB 3R53F	30023063	1
37	Switch Board 3343	30044305	1
38	Receive Board 3L53	30044304	1
39	Transformer SC25A	43110168	1
40	AC Contactor FMC-O	44010220	1
	AC Contactor LC1K0910M7	44010199	1
41	Capacitor 4.5uF/450VAC	33010012	1
42	Terminal Board T5A0A-77	42011209	1
43	Air Louver	10514212	6
44	Air Outlet Assy	20004201	1
45	Air Guider	10514213	6
46	Swing Motor	15214215	1
47	Panel Assy	20004215	1
48	Light Picture	\	1
49	Plastic Pipe	05230022	1
50	Remote Controler Y512	\	1
51	Power Cable	40020290	1
52	Connect Cable	40020419	1
53	Power Cable	\	1
54	Signal	40032147	1
55	Signal	40032139	1
56	Room Sensor	\	1
57	Tube Sensor	\	1
58	4 Core Sensor	39000171	1
59	17 Core Connect cable	40030056	1

OUTDOOR UNIT

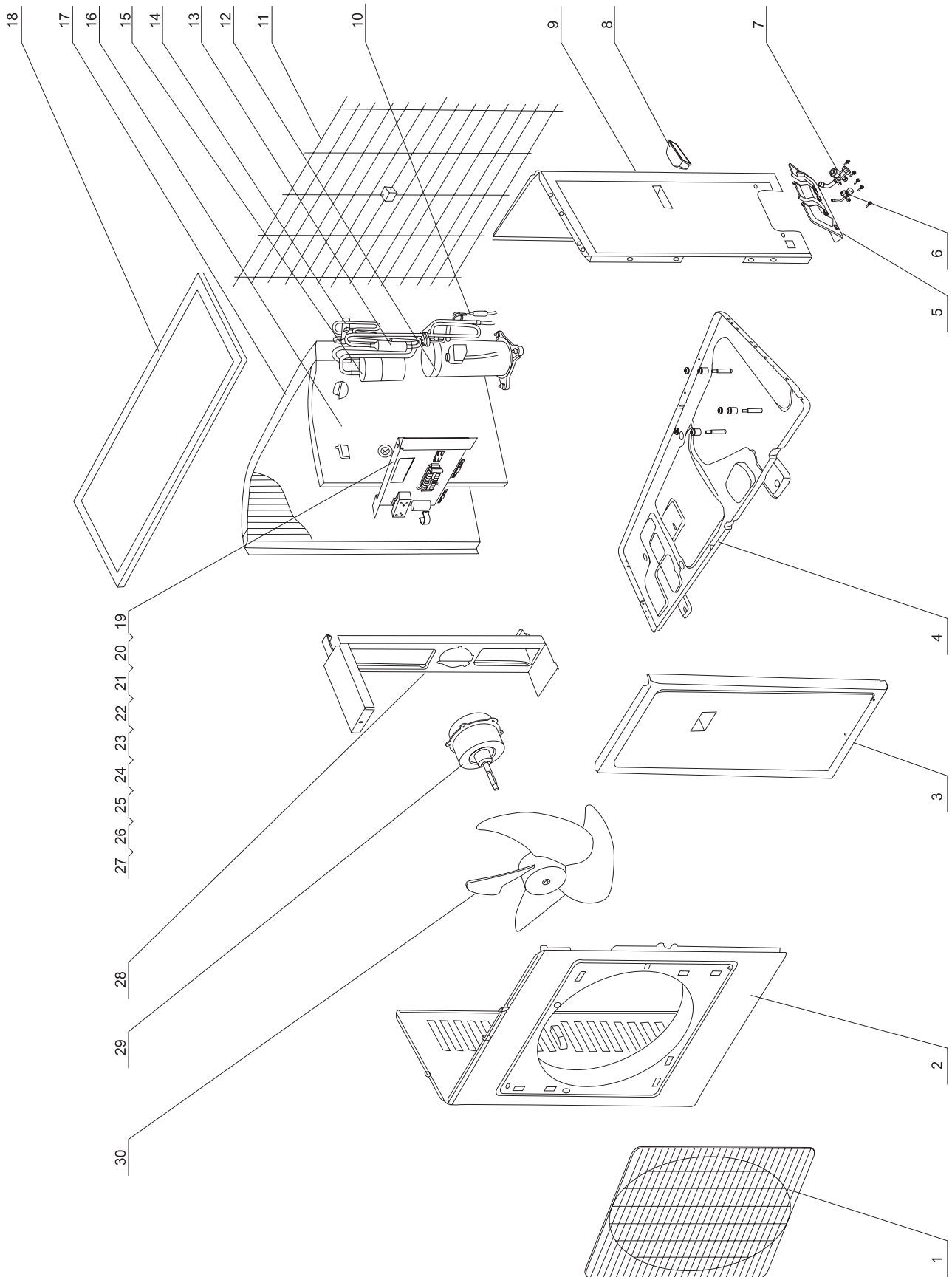

Model No: AC-F30HG
Version 1.0

OUTDOOR UNIT

No.	Description	Part no	Qty
1	Front Grill	22265250	1
2	Front Plate	01435254	1
3	Front Side Plate	01305018	1
4	Metal Base	01205011	1
5	Valve Support	01715001	1
6	Liquid Valve Assy	07105256	1
7	Gas Valve Assy	07105252	1
8	Handle	26235253	1
9	Rear Side Plate	01305260	1
10	Pressure protection switch	46020003	1
11	Rear grill Assy	01475251	1
12	Compressor	00100503	1
13	Silencer	07245201	1
14	4 Way Valve	43000310	1
15	Gas-liquid Separator	07255251	1
16	Isolation Sheet Assy	01235253	1
17	Condenser Assy	01105035	1
18	Top Cover Assy	01255260	1
19	Electric Box	01405201	1
20	Cable Clamp	71010102	1
21	Insulating Iiece	70410523	1
22	Fan Capacitor 3uF/450V	33010021	1
23	AC Contactor 3TF4211 3TF4111-1RMO	44010205	1
24	Terminal Board T6C0A	42011230	1
25	Over Current Protector UO-10-9.0A	46020108	1
26	AC Relay VC15-3A1B- AC220	44020305	1
27	Velometer	30117001	1
28	Motor Support	01705252	1
29	Motor LW60B	15015205	1
30	Axial Flow Fan	10335253	1
31	Room Sensor	39000219	1

INSTALLATION GUIDE

Location

1. Do not place object near the air outlet so that conditioned air can reach the whole room.
2. Be sure to install the indoor unit firmly and horizontally.
3. Select the place that can support 4 times of the indoor unit's weight and will not increase noise and vibration.
4. Select a place easy to drain water and connect with the outdoor unit.
5. Make sure there is enough space for maintenance and make sure the distance between the unit and ground is 1.8m or more.
6. Make sure the suspension bolt pitch can hold 4 times of the indoor units's weight, otherwise, you should strengthen the suspension bolt pitch.

Note:

1. Keep enough distance from the kitchen.
2. The appliance shall not install in the laundry.

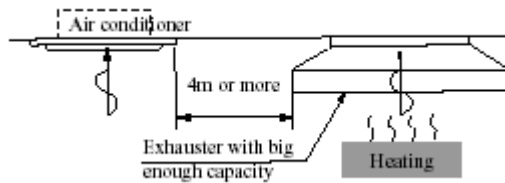

Ceiling opening and suspension bolt (M10) pitch dimension.

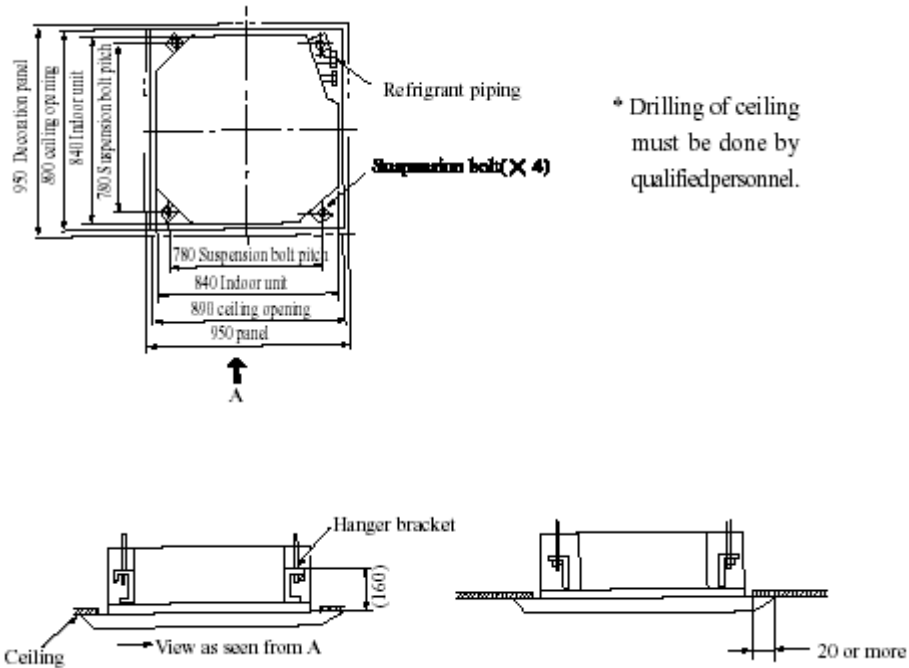

Note

Installation is possible with a ceiling dimension of 890 (marked with * can be 910), but the ceiling-panel overlapping dimension must be 20mm or more.

Indoor unit installation

1. Install the indoor unit temporarily.
 - a. Attach the hanger bracket to the suspension bolt. Be sure to fix it securely by using a nut and washer from the upper and lower sides of the hanger bracket. The washer fixing plate will prevent the washer from falling.
 - b. Refer to the paper pad for installation for ceiling opening dimension.
 - c. The center of the ceiling is indicated on the paper pad for installation, the center of the unit is indicated on the label attached to the unit and on the paper pad for installation.
 - d. Fix the paper pad to the unit with screws (3)
2. Refer to diagram 3, adjust the unit to the right position for installation.
3. Check if the unit is horizontally level.
 - a. The indoor unit is equipped with a built-in drainage pump and float switch at each of the unit's 4 corners, verify that it is level by using a water level or a water filled vinyl tube. (If the unit is tilted against condensate flow the float switch may malfunction and cause water to drip.)
4. Remove the washer fixing plate used for preventing the washer from falling and tighten the upper nut.
5. Remove the paper pad for installation

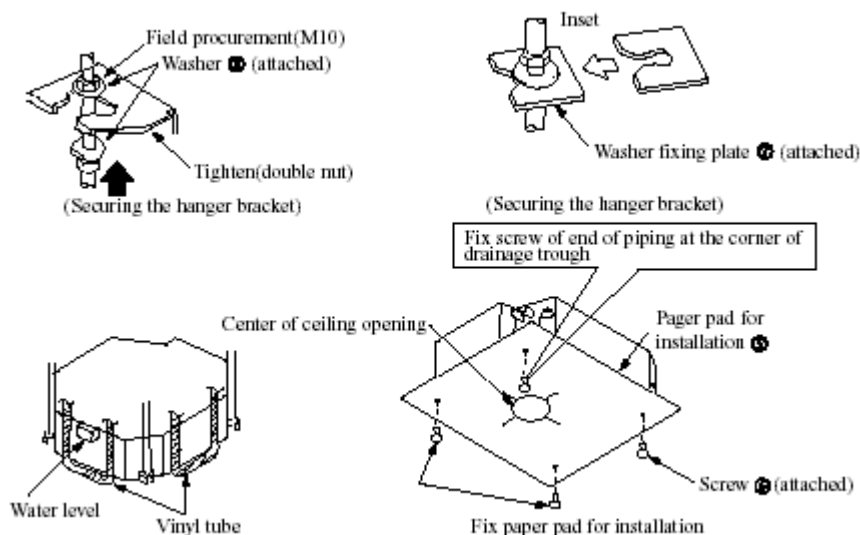

Warning: Tighten the nut to prevent the unit from falling.

Connection of refrigerant pipe

- Be sure to use both a spanner and torque wrench together as shown in the drawing, connecting or disconnecting pipes to/from the unit.
- Refer to table 1 to determine the proper tightening torque (over tightening may damage the flare and cause leaks.)
- When connecting the flare nut, coat the flare both inside and outside with refrigerating machine oil and initially tighten by hand 3 or 4 turns.
- Check the pipe connector for gas leaks, then insulate it as shown in the drawing below.
- Use sealing pad (11) to wrap joint between gas pipe and the insulation (8).

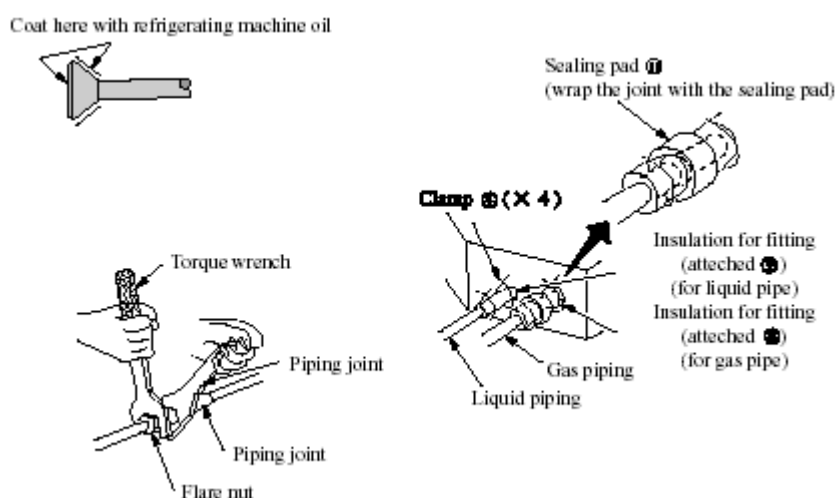

Table 1

Pipe gauge	Tightening torque		Notes
9.52	30 ~ 40N.m	KF(R)-50TW/E1	Add 30g
16	60 ~ 65N.m	KF(R)-70TW/B	Add 30g
12	45 ~ 50N.m	KF(R)-70TW/B1	Add 30g
19	70 ~ 75N.m	KF(R)-120TW/B	Add 30g

The maximum length for refrigerant piping is 25 meters, when the length exceeds 10 meters, you should charge additional (refrigerant as shown in following for per-meter added).

Drainage pipe

1. Installation of drainage pipe.
 - a. The diameter of the drainage pipe should be greater than or equal to the diameter of the connecting pipe [vinyl tube, pipe size: 25mm (outer dimension)]
 - b. Keep the drainage pipe short and sloping downwards at a gradient of at least 1/100 to prevent air pockets from forming.
 - c. If the drainage hose cannot be sufficiently set on a slope, add a drainage-raising pipe.
 - d. To keep the drainage hose from sagging, keep space between hanging hooks at 1 1.5m.

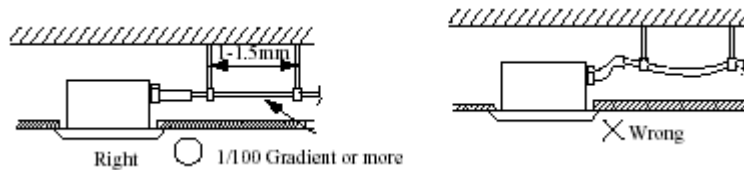

- e. Use the attached drainage hose and clamp. Insert the drainage hose into the drainage socket up to the grey tape. Tighten the clamp until the screw head is less than 4 mm from the hose.
- f. Wrap the big sealing pad around clamp of the drainage hose to insulate.
- g. Insulate the drainage hose inside the room.



Precautions for drainage raising pipe

1. Install the drainage-raising pipe at a height of less than 280 mm.
2. Install the drainage-raising pipe at a right angle to the indoor unit and no more than 300 mm from the unit.

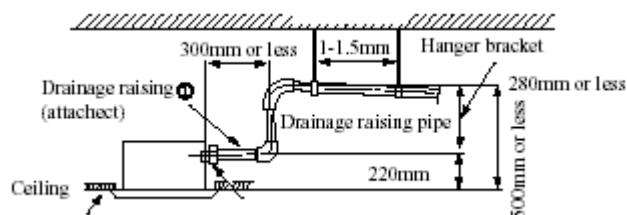

Note

The incline of attached drain hose should be 75mm or less, so that the drainage socket does not have to stand additional force.

If converging multiple drainage pipes, install according to the procedure shown below.

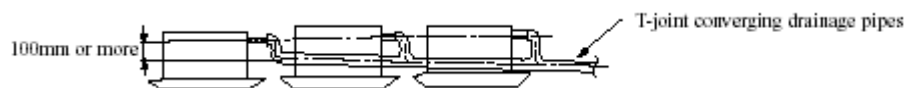
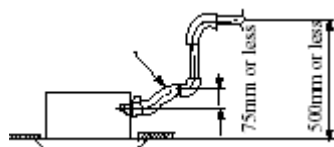

Select converging drainage pipes whose gauge is suitable for the operating capacity of the unit.

- 2 After finishing installation, check if drainage water flows smoothly.
 - a. Add approximately 600 cc of water to the drainage trough through air outlet or inspection hole slowly and check drainage flow.
 - b. When electric wiring is finished, check drainage flow during cooling operation.

Method of adding water

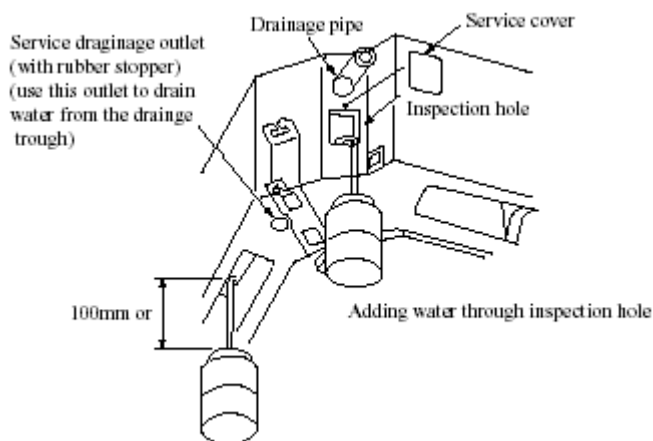

Warning:

Before obtaining access to terminals, all supply circuits must be disconnected.

Electric wiring

- All field supplied parts and materials must conform to local laws and regulations.
- For electric wiring, refer to WIRING DIAGRAM ”attached to the unit body.
- A skilled technician must perform all wiring.
- A circuit breaker capable of shutting down power supply to the entire system and with at least 3 mm contact separation must be installed.
- Earth properly.
- Wiring must conform to national laws and regulations.
- Installing the protector with not more than 30mA leakage current is a must.
- If the supply cord is damaged, it must be replaced by the manufactory or its service agents or a similarity qualified person in order to avoid a hazard.

Wiring of unit and the controller

- Wiring of the indoor unit.
- Remove the control box lid (1), pull the wires inside through rubber bush and wiring according to the “ WIRING DIAGRAM ”, then tighten it with clamp.
- Wiring of the controller.
- Remove the control box lid (2), pull wires inside through rubber bush and connect to the controller.
- Wrap the wire with sealing pad (12).
- After wiring, tighten it with clamp and fix the control box lid (1),(2).
- Heating and cooling connect the rubber wire (5-cords) to the power supply terminal board in properly.
- Cooling connect the rubber wire (3-cords) to the power supply terminal board properly.

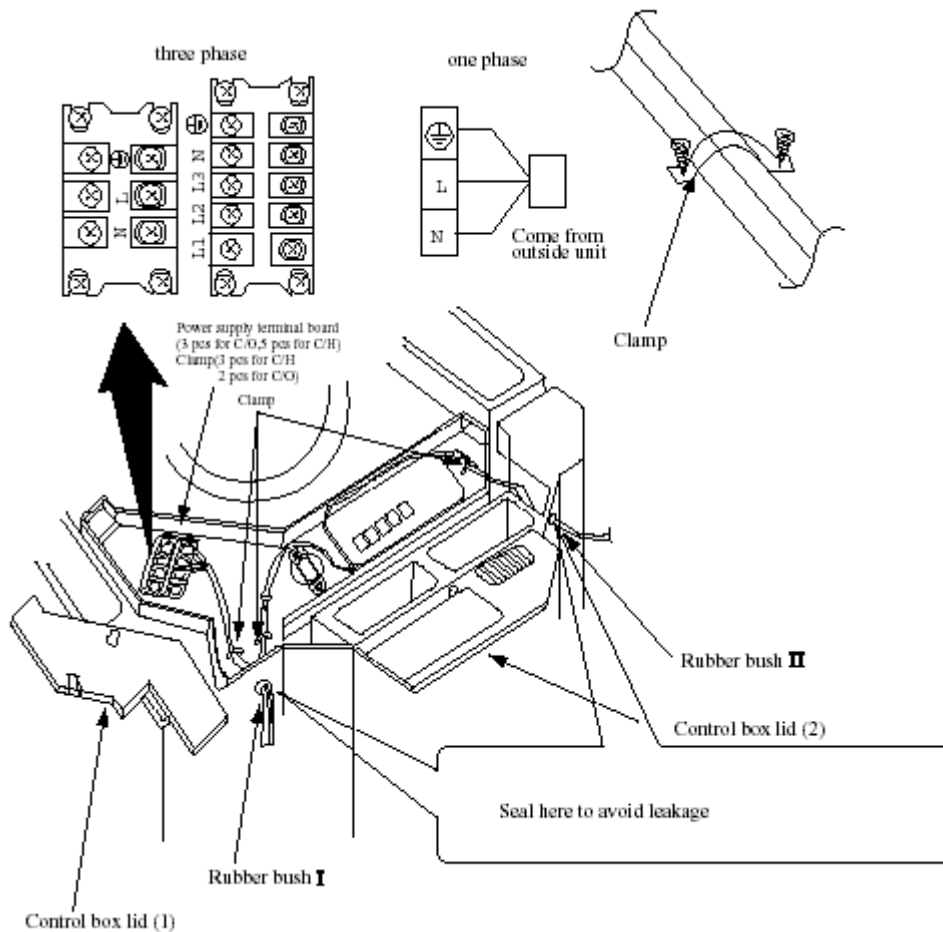

Precautions:

Be sure to connect the indoor unit and outdoor unit at right poles.

Installation of panel

1. Set the panel to the indoor unit body by matching the position of the swing flap motor of the decoration panel to the piping position of the panel to the piping position of the indoor unit as shown in fig.4.
2. Install the decoration panel
 - a. Hang the latch, which is located on the opposite side of the swing flap motor on the panel, temporarily to the book of the indoor unit. (2 Positions)
 - b. Temporarily hang the remaining 2 latches to the hooks on the sides of the indoor unit.(be careful not to let the swing motor lead wire get caught in the sealing material.)
 - c. Screw all 4 hexagon head screws located right beneath the latches in approximately 15mm.(panel will rise)
 - d. Adjust the panel by turning it to the arrowed direction in Fig.4 so that the ceiling opening is completely covered.
 - e. Tighten the screws until the thickness of the sealing material between the panel and the indoor unit body is reduced to 5 8 mm.

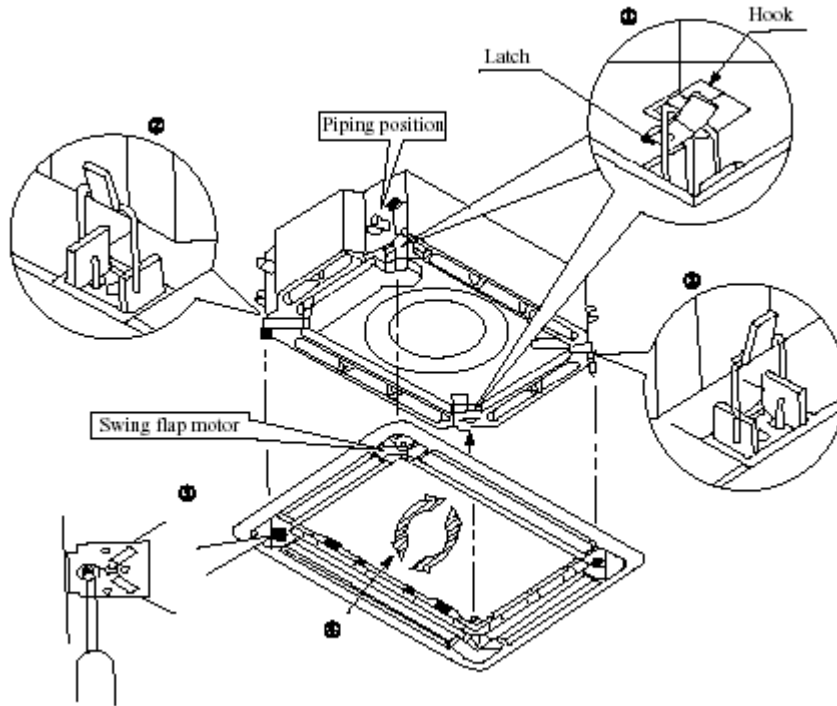

(Fig.4)

Precautions

- 1 Improper screwing of the screws may cause the troubles shown in Fig.5.

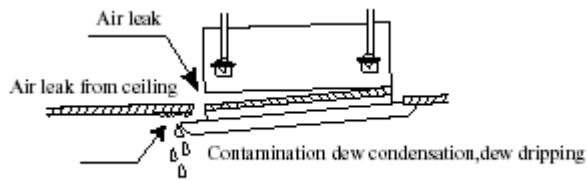

(Fig.5)

2. If gap is still left between the ceiling and the panel after screwing the screws, readjust height of the indoor unit body (Refer to Fig.6).

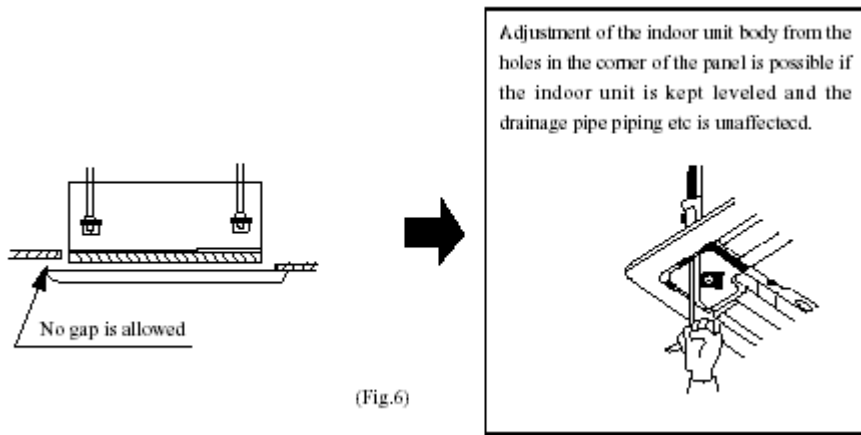

- After fixing, be sure no gap left between the ceiling and the panel.
3. Wiring of the decoration panel.
Connect the joints for swing flap motor lead wire (at 2 places) installed on the panel (Refer to Fig.7).

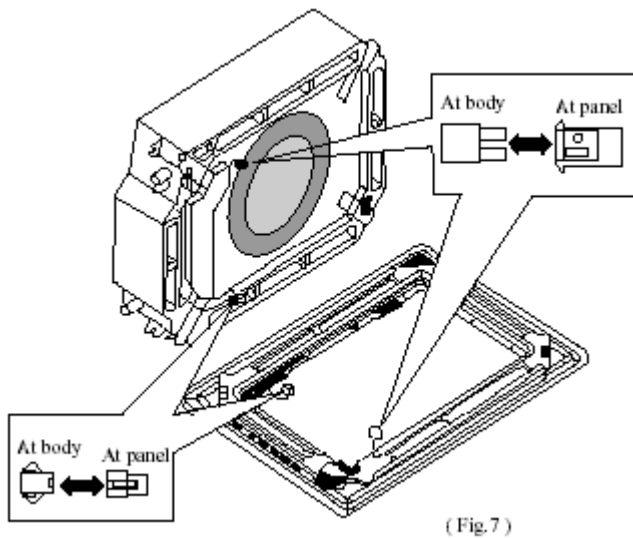

Selecting installation site

- Select an installation site where the following conditions are satisfied and that meets with your customer's approval.
- Places which are well-ventilated.
- Safe places which can withstand the unit's weight and vibration and where the unit can be installed level.
- Places where the unit does not bother next-door neighbors.
- Places where there is no possibility of flammable gas leak.
- Places where things distressed in water do not exist because water drains off the outdoor unit.
- Places where servicing space can be well ensured.
- Places where strong wind can not blow directly to outdoor unit.

Outdoor unit installation

- 1 Install the unit firmly with combination of M10 or more bolts and nuts on the foundation that can fully support the weight of the unit and make sure the unit stand vertically.
- 2 Do not installing the unit on the top of building.
- 3 If there is noise caused by vibration add rubber between the unit and the foundation, Please.
- 4 When the air conditioner is heating or defrosting, drain water of the outdoor unit to an appropriate place with the drain hose.
- 5 Fixing method: Fix the outdoor drainage hose head in the hole of the chassis, then connect the drainage hose with the mouth of drainage pipe.

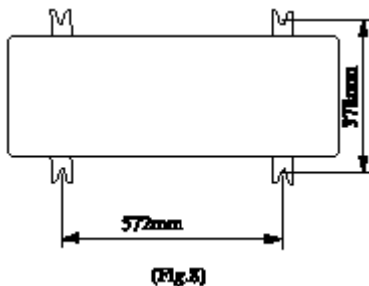

Connecting the pipe.

1. Remove the flare nuts of the valves.
2. Match the piping center, tighten the flare nuts with hand.
3. Tightening the flare nuts with a driver.
4. Remove the nuts of one-way valve.
5. If possible, evacuate from the one-way valve with a vacuum pump. (Fig.9)
6. Tighten the nuts, then check whether there is gas leaking out.

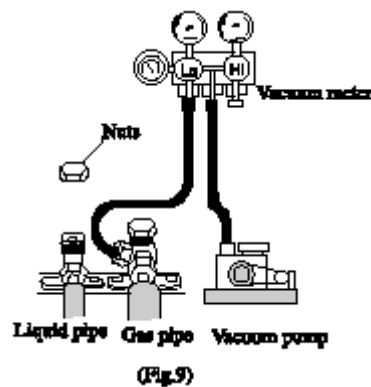

Electric wiring

1. Read the name plate carefully, then arrange wiring according to the “WIRING DIAGRAM ”
2. A circuit breaker capable of shutting down power supply to the entire system must be installed.
3. Earth properly.
4. All wiring must be performed by a skilled electrician according to the “ WIRING DIAGRAM ”.
Wrong wiring may cause fire or electric shock.

Connect the power connecting wires

1. Remove the front side plate (Fig.10).
2. Break through the hole for wires and put on rubber bush.
3. Pull all wires through the rubber bush.
4. Connect the outdoor unit according to the “WIRING DIAGAM” of outdoor unit. Make sure to wire firmly.
5. Tighten the wires with clamp and clasp.

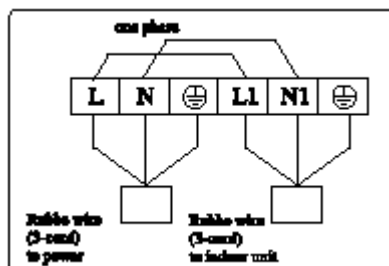

Note

1. Earth the units firmly.
2. Wire the units firmly.
3. Don't pull the connector too forcefully.
4. For cooling only type: Connect the rubber wire (3-cords) to L.N1 of the power supply terminal board (8p) and the rubber wire (5-cords) to L1, L2 ,L3, N, of the power supply terminal board (8p) accordingly.
For cooling/heating type: Connect the rubber wire (5-cords) to the power supply terminal board (5p) properly.
5. Connect the other wires properly. Do not pull the wire when fixing it with wire clamp and clasp. Do not let the wire too loose in the outdoor unit.

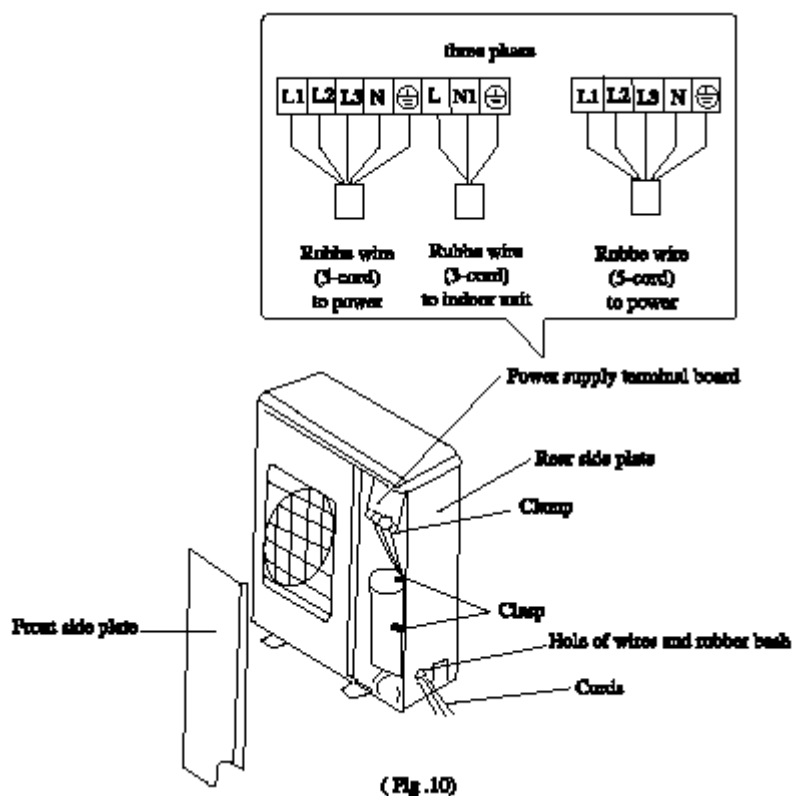

Test operation

1. Prepare for test
 - a. Do not turn on the power switch before all installation is finished.
 - b. Connect wires correctly and firmly.
 - c. Open the check valve.
 - d. Remove all dust.
2. Testing
 - a. Turn on the power switch and press “1/0” button.
 - b. Press “MODE” button select COOL, HEAT, FAN, etc to test whether it operates normally.
3. Emergency operation.
 - a. When the batteries fail or when the remote controller is missing, operate as shown below.
 - i. On stopping you can press the “AUTO” button on cover NO until it is in “AUTO” mode. The air conditioner select from COOL, HEAT, DRY, FAN modes automatically.
 - ii. On operating, press the “AUTO” button, the air conditioner will stop.

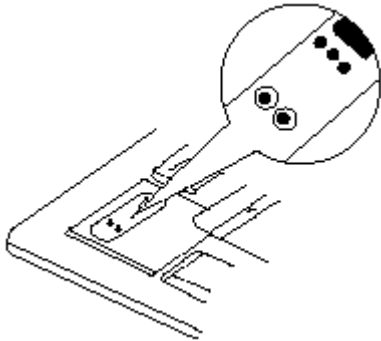

Note:

The TEST” button on the cover no is specially for testing the air conditioner.

When pressing it, the air conditioner will be forced to operate or stop. Do not press it when air conditioner is in normal operation.

For the following items, take special care during construction and check after installation is finished.

Items to check	If not properly done, what is likely to happen
Is the indoor unit fixed firmly?	The unit may drop, vibrate or make noise.
Is the gas leak test finished?	It may result in insufficient cooling.
Is the unit fully insulated?	Condensate water may drip.
Does drainage flow smoothly?	Condensate water may drip.
Does the power supply voltage correspond to that shown on the nameplate	The unit may malfunction or the components burn out.
Are wiring and piping correct?	The unit may malfunction or the components burn out.
Is the unit safely grounded?	Risk of electric leakage.
Is wiring size according to specifications?	The unit may malfunction or the components burn out.
Is something blocking the air outlet or intake of either the indoor or outdoor units?	It may result insufficient cooling.
Have records of refrigerant piping length and additional refrigerant charge been made?	Volume of refrigerant charge in the system is not clear.

Note to the installer

Be sure to instruct the customer how to operate the system and show him/her the attached operation manual.

CIRCUIT DIAGRAM

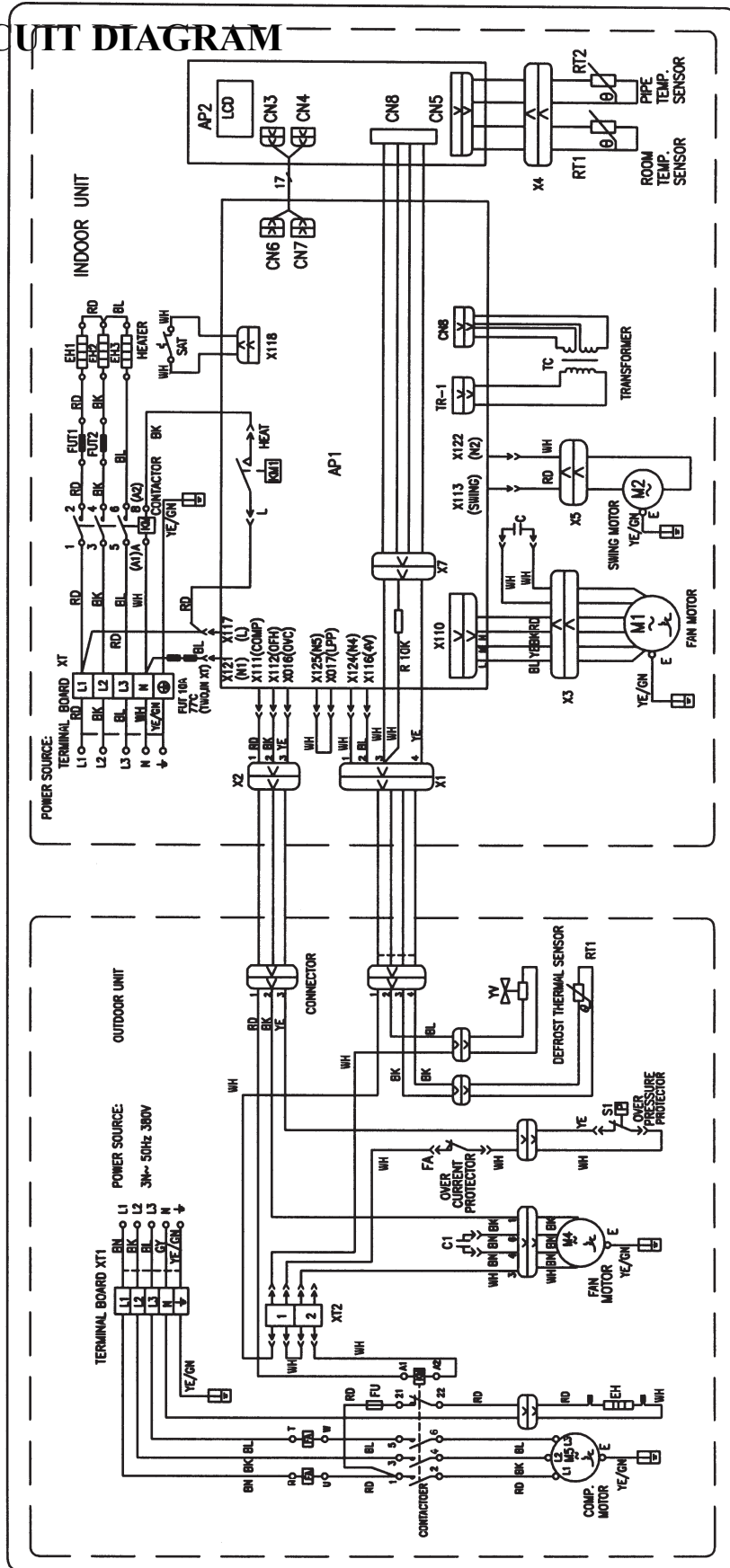

Model No: AC-F30HG
Version 1.0

PCB FUNCTION MANUAL

1. Running mode:

- a. COOL
- b. DRY
- c. FAN
- d. HEAT
- e. AUTO.

2. Controlling contents:

- a. Indoor unit fan motor (high middle and low speed);
- b. Sweep fan motor;
- c. Electrical heater;
- d. Outdoor unit fan motor (high and low speed);
- b. Reversing valve;
- c. Compressor;
- d. Water pump;
- e. Fresh air fan motor;
- f. Anion creator.

3. The parameter to be input:

- a. The ambient temperature of the indoor unit (shorten form is T_{in});
- b. The evaporator temperature of the indoor unit (shorten form is T_{eva});
- c. The condenser temperature of the outdoor unit (shorten form is T_{con});
- d. The ambient temperature of the outdoor unit (shorten form is T_{out});
- e. The temperature of gas output from the compressor (shorten form is T_{output}).

4. The different controlling mode for the different function mode:

Under all of the modes, the compressor will continue work for 6min once it starts (except for the protection of full-water), and be restart in 4min after it stops. At the beginning, the indoor unit fan motor runs for 8sec in high speed, then change to the set fan speed; and it is same in the outdoor unit.

a. Cooling mode:

If $T_{in} \geq T_{set} + 1^{\circ}\text{C}$, cooling mode act, compressor and outdoor unit run, and indoor unit run in the set speed;

If $T_{in} \leq T_{set} - 1^{\circ}\text{C}$, the unit will be stop from cooling mode, compressor and outdoor unit stop, and indoor unit still run in the set speed;

If $T_{set} - 1^{\circ}\text{C} < T_{in} < T_{set} + 1^{\circ}\text{C}$, keep running in the old mode; In the cooling mode, the range of T_{set} is $16^{\circ}\text{C} \sim 30^{\circ}\text{C}$.

Outdoor fan motor working state:

$T_{out} \geq 27^{\circ}\text{C}$, outdoor fan motor runs in high speed;

$T_{out} \leq 24^{\circ}\text{C}$, outdoor fan motor runs in low speed;

$24^{\circ}\text{C} < T_{out} < 27^{\circ}\text{C}$, outdoor fan motor runs in old mode.

b. Drying mode:

If $T_{in} > T_{set} + 2^{\circ}\text{C}$, drying mode act, compressor, indoor unit fan motor run, the indoor unit fan motor runs in low speed;

If $T_{set} - 2^{\circ}\text{C} \leq T_{in} \leq T_{set} + 2^{\circ}\text{C}$, compressor, indoor unit and outdoor run for 6 min, then stop for 3 min, then run by this cycle, the indoor unit fan motor runs in low speed;

If $T_{in} < T_{set} - 2$, compressor, outdoor unit fan motor, indoor unit fan motor stop.

In drying mode, the range of T_{set} is $16^{\circ}\text{C} \sim 30^{\circ}\text{C}$.

Outdoor fan motor working state:

$T_{out} \geq 27^{\circ}\text{C}$, outdoor fan motor runs in high speed;

$T_{out} \leq 24^{\circ}\text{C}$, outdoor fan motor runs in low speed;

$24^{\circ}\text{C} < T_{out} < 27^{\circ}\text{C}$, outdoor fan motor runs in old speed.

c. Heating mode:

If $T_{in} \leq T_{set} + 1^{\circ}\text{C}$, heating mode act, reversing valve, compressor and outdoor unit fan motor run, indoor unit fan motor runs in the set speed and the condition of avoiding the cold wind;

If $T_{in} \geq T_{set} + 3^{\circ}\text{C}$, compressor and outdoor unit fan motor stop, reversing valve is still electric, the indoor unit fan motor runs in the condition of flowing the rest heat;

If $T_{set} + 1^{\circ}\text{C} < T_{in} < T_{set} + 3^{\circ}\text{C}$, keep running the old mode;

In the heating mode, the range of T_{set} is $16^{\circ}\text{C} \sim 30^{\circ}\text{C}$.

In the heating mode, the valve will be electroless in 2 min after the unit is turned off.

The working condition of the outdoor unit:

$T_{out} \geq 16^{\circ}\text{C}$, the outdoor unit fan motor runs in low speed;

$T_{out} \leq 13^{\circ}\text{C}$, the outdoor unit fan motor runs in high speed;

$13^{\circ}\text{C} < T_{out} < 16^{\circ}\text{C}$, the outdoor unit fan motor runs in the old speed; the outdoor unit fan motor stop when it is defrosting.

The conditions of avoiding cold wind:

The indoor unit adjust the guider into horizontal first, indoor unit motor runs in high speed for 8 sec, then runs in low speed.

- a. Compressor runs as soon as T_{in} achieve the temperature of starting unit, indoor unit runs at low speed, guider is still horizontal, 30sec later, indoor unit fan motor runs in the set speed, guider run in the set mode (it run in the max angle if it has not be set);
- b. If T_{in} does not achieve the temperature of starting unit, indoor unit fan motor runs in the low speed and guider is horizontal.

The conditions of flowing the rest heat:

Once the compressor is stop, guider turn into horizontal, the indoor unit fan motor runs in low speed.

The conditions of beginning defrosting:

After the unit continue heating for 44min, and detect $T_{con} \leq -8^{\circ}\text{C}$ for 1min, the defrosting mode act, guider turn into horizontal, the reversing valve, the indoor and outdoor unit fan motor stop. If there is electrical heater in the unit, then it will be stopped first after 1min, reversing valve, the indoor and outdoor unit fan motor stop.

The conditions of stopping defrosting:

After the unit continue defrosts for 10min or $T_{con} + 10^{\circ}\text{C}$, the defrosting stop, the reversal valve run, the outdoor fan motor runs, and the indoor unit fan motor will run in the condition of avoiding the cold wind.

The working conditions of electrical heater:

When the indoor unit fan motor runs in high or middle speed and compressor runs, and $T_{eva} \leq 44^{\circ}\text{C}$ and $T_{in} \geq 23^{\circ}\text{C}$, or $T_{in} < T_{set} - 1^{\circ}\text{C}$, the electrical heater act.

When the indoor unit is stop or runs in low speed or compressor in stop, or $T_{eva} \geq 52^{\circ}\text{C}$, or $T_{in} \geq 26^{\circ}\text{C}$, or $T_{in} \geq T_{set} + 2^{\circ}\text{C}$, the electrical heater stop and will restart after 2min.

d. Fanning mode:

The indoor unit fan motor runs in the set speed:

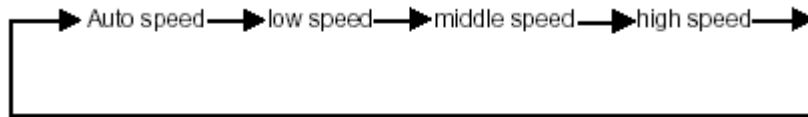

The range of set temperature 16°C ~ 30°C.

e. Auto mode:

It runs, according the T_{in} .

If $T_{in} > 26^{\circ}\text{C}$, cooling mode act, the T_{set} is 26°C automatically;

If $20^{\circ}\text{C} < T_{in} < 26^{\circ}\text{C}$, drying mode act, the T_{set} is 24°C automatically;

If $T_{in} < 20^{\circ}\text{C}$, heating mode act, the T_{set} is 20 automatically till $T_{in} < 24$.

If the unit is cooling only, when $T_{in} < 20$, fanning mode act, the T_{set} is 20 automatically till $T_{in} < 24$.

Once the each mode act, it will be in 30sec to change to the auto mode according. the T_{in} .

5. Timer and sleep mode:

1. Sleep mode:

If it is cooling or drying, in 1hour of the beginning, the T_{set} will be increased 1°C automatically, and it will be increased 1°C automatically after 2hour from the beginning, then the unit runs in this temperature.

If it is heating, in 1hour of the beginning, the T_{set} will be decreased 1°C automatically, and it will be decreased 1 automatically after 2hour from the beginning 2, then the unit runs in this temperature.

There is no sleep mode when fanning and auto mode act.

2. Timer for turn on:

The unit is stop when the timer for turn on is acted, when it is time to turn on, the controller will act in the set mode. The distance of setting twice is 0.5hour, and the range time is 0.5~24 hour.

3. Timer for turn off:

The unit is run when timer for turn off is acted, the unit is stop, when it is time to turn off. The distance of setting twice is 0.5hour, and the range time is 0.5~24 hour.

6. Other function

1. Sweeping:

It controlled by the “sweep” button of the remote controller. It is available when the indoor unit fan motor is run.

2. Buzzer function:

It will be acted and have a sound when the controller is turned on or received a right signal.

3. Auto fan speed of indoor unit motor:

The indoor unit fan motor will run by the rules till it runs for 30sec after the unit is turned on.

When heating act:

If $T_{in} \geq T_{set} + 2^{\circ}\text{C}$, the indoor unit fan motor runs in low fan speed;

If $T_{in} \leq T_{set} + 1^{\circ}\text{C}$, it is in middle fan speed;

If $T_{in} < T_{set} - 1^{\circ}\text{C}$, it is in high fan speed.

When cooling act:

If $T_{in} \leq T_{set}$, it is in low fan speed;

If $T_{in} \geq T_{set} + 1^{\circ}\text{C}$, it is in middle fan speed;

If $T_{in} > T_{set} + 3^{\circ}\text{C}$, it is in high fan speed.

When fanning act:

If $T_{in} \leq T_{set}$, it is in low fan speed;

If $T_{in} \geq T_{set} + 1^{\circ}\text{C}$, it is in middle fan speed;

If $T_{in} > T_{set} + 3^{\circ}\text{C}$, it is in high fan speed.

4. Indicator light:

- a. Running indicate light: it turn on when the unit is turned on and turn off when the unit is turned off.

It will be flashing when: Defrosting, avoiding the cold wind, protecting of full-water tank.

- b. Timer light: it turn on when the timer is set or the unit is in the mode of sleeping except the unit is off.

It will be flashing when: Protecting of the compressor in high-pressure, protecting of the compressor in low pressure, protecting of the low power supply, protecting of the high-temperature of the compressor outlet pipe.

- c. Compressor light: it turn on when the compressor runs, and it turn off when the compressor stop.

7. Safeguard:

1. Protecting of avoid freezing:

When cooling drying act:

After the compressor started and running for 5min, and detect $T_{eva} \leq -4^{\circ}\text{C}$ for 1min, running indicate light will flashing, compressor and the outdoor unit fan motor stop, the indoor fan motor and sweep fan run in old mode; when the compressor stop for 10 min, and detect $T_{eva} \geq 15^{\circ}\text{C}$, running indicate light turn off, controller runs in set mode.

When protecting of avoid freezing, button is not shielded.

2. Protecting of compressor high-pressure:

When detect protecting of high-pressure for 3sec, turn off load except water pump, shield all button and signal of remote control, timer indicate light will flashing; when detect no protecting of compressor high-pressure for 6sec, remove shielding function, timer indicate light will flashing, after press ON/OFF to turn off unit, turn off indicate light, When press ON/OFF, then restart running.

3. Protecting of compressor low-pressure:

- a. After compressor start for 3min, begin to detect signal of low-pressure switch, if detect that low-pressure switch turn off for 3min, then the unit stop, timer indicate light will flashing, after 3min the unit renew to run automatically; if protecting of low-pressure switch continually appear times, timer indicate light will flashing, and the unit can not renew automatically, in order to awake user that the unit leak refrigerant; after press ON/OFF, the unit turn off, press ON/OFF again, renew to run;
- b. When frosting act, the unit do not detect signal of low-pressure switch. After finish frosting for 10min, to start to detect;
- c. At the same time, press the force key and auto key of controller, shield to detect signal of low-pressure switch, so that reclaim refrigerant, after 6min, renew detecting automatically, or press ON/OFF key to turn off the unit, after press ON/OFF key again, renew detecting;
- d. When heating act, if $T_{out} \leq -0^{\circ}\text{C}$, shield detect low-pressure switch;
- e. When heating act, compressor run, and the outdoor fan motor stop (protecting of avoid high temperature), shield detect low-pressure switch, after the outdoor fan motor renew to run, start to detect signal of low-pressure switch;
- f. When compressor stop, if detect that low-pressure switch turn off for 30sec, then the unit turn off, timer indicate light will flashing, can not renew automatically. After press ON/OFF key, the unit turn off, if press ON/OFF key, then renew to run unit.

4. Protecting of discharge pipe high temperature:

After compressor starts, if detect that T_{con} higher than T_2 ($T_2=120^{\circ}\text{C}$, 125°C , 130°C , different jump-thread) for 30sec, or discharge pipe temperature sensor have any trouble, timer indicate light flash.

The unit stops as if T_{in} reach T_{set} .

After compressor stops for over 3min, if $T_{con} < 90^{\circ}\text{C}$, then the unit renew to run. If this protecting phenomenon happens twice continually, and the unit can not renew automatically, timer indicate light flashes. Press ON/OFF key to turn off the unit, press ON/OFF key again, if $T_{con} < 90^{\circ}\text{C}$, the unit can run in set mode, otherwise timer indicate light still flashes.

5. Protecting of indoor exceed high temperature:

When heating act, if detect $T_{eva} \geq 56^{\circ}\text{C}$ for 5 sec, the outdoor unit fan motor stops, if $T_{eva} \leq 51^{\circ}\text{C}$, the outdoor unit fan motor startups. If $T_{eva} \geq 100^{\circ}\text{C}$, the indoor unit fan motor automatically turn to high speed; If $T_{eva} \leq 48^{\circ}\text{C}$, the indoor unit fan motor turn to old set speed.

6. Protecting of low power:

When compressor starts, if detect electric current higher than 25A for 3sec, the unit stop as if T_{in} reach to T_{set} . After compressor stops for over 3min, then the unit renew old running state, protection exceed six times (if compressor runtime exceed 6min, protection time set 0), timer indicate light flashes, the unit can not renew old state automatically. After press ON/OFF key, the unit turn off if press ON/OFF key again, then renew to run unit.

7. Protecting of water pump control and water full:

- a. When cooling or drying act, compressor runs, at the same time water pump runs.
- b. When the unit is turned off or turned off in cooling mode, or in drying, or turn to other mode, water pump is still working for 5 minutes, then drop electricity
- c. When detect water full signal, water pump must run no matter mode.
- d. When the unit is running or the unit runs in compulsory cooling or compulsory heating, if detect water full signal for 8sec, the unit runs into protecting of water full, running indicate light flashes; when cooling or compulsory cooling act, the outdoor unit fan motor and compressor stop, the indoor unit fan motor stops 1min later; when drying act, all control signal turn off; when heating or compulsory heating act, turn off all load except for 4-way valve, the indoor unit fan motor stops 1min later; when fanning act, the indoor unit fan motor stops 1min later.
- e. In water full protection, if detect no water full signal and water pump works for 10 minutes, it turns off water pump; if water pump doesn't work for 10 minutes, it works to ten minutes and cut off.
- f. When water full signal is removed.
- g. Press ON/OFF button to turn off the unit, press it to restart, and exit protection state. If water full signal can not be remove for 2hour, stop sending power to water pump.

8. Buttons:

If you use remote control, and its display mode is HEAT mode, but machine is cooling only, it will run in fanning mode.

a. TEST button:

When the unit is running, after press this button, the unit forcibly be been into cooling mode, turn on all load except for 4-way valve, the indoor unit fan motor and the outdoor unit fan motor run in high speed. If the unit is not running, after press this button for 1sec, the unit forcibly be been into heating mode, turn on all load, the indoor unit fan motor and the outdoor unit fan motor run in high speed. If detect T_{in} (or T_{eva}) -10°C or T_{in} (or T_{eva}) 80°C , buzzer beeps, when the unit is running, after press this button, the unit turns off.

b. Auto button:

When the unit is in stop state, after press this button, the unit runs in auto mode; when the unit is in running state, after press this button, the unit turns off;

9. Auto-restart function:

Memory content: mode, swing, set temperature, set speed. The unit can restart automatically according to memorizing previous state after break electricity, compressor will 3min delay in first restart.



Большая библиотека технической документации

<https://splitsystema48.ru/instrukcii-po-ekspluatacii-kondicionerov.html>

каталоги, инструкции, сервисные мануалы, схемы.